



Bain-Marie
Models FW-CN-0905, 1170, 1435
Items 42156, 42157, 43055
Instruction Manual



STOP
DO NOT RETURN
THIS PRODUCT TO THE STORE

For questions or assistance with this product call OMCAN Toll Free:
1 800 465 0234
Customer Service
or
visit the Support section of
www.omcan.com

Revised - 06/23/2022



Toll Free: 1-800-465-0234
Fax: 905-607-0234
Email: service@omcan.com
www.omcan.com

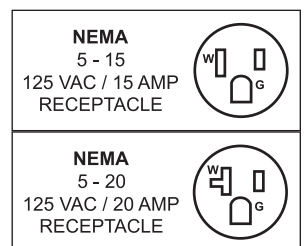

Table of Contents

Model FW-CN-0905 / Model FW-CN-1170 / Model FW-CN-1435

Section	Page
General Information -----	3 - 4
Safety and Warranty -----	4 - 5
Technical Specifications -----	6
Operation -----	6
Maintenance -----	6
Parts Breakdown -----	7 - 8
Electrical Schematics -----	9
Notes -----	10
Warranty Registration -----	11



General Information

Omcan Manufacturing and Distributing Company Inc., Food Machinery of America, Inc. dba Omcan and Omcan Inc. are not responsible for any harm or injury caused due to any person's improper or negligent use of this equipment. The product shall only be operated by someone over the age of 18, of sound mind, and not under the influence of any drugs or alcohol, who has been trained in the correct operation of this machine, and is wearing authorized, proper safety clothing. Any modification to the machine voids any warranty, and may cause harm to individuals using the machine or in the vicinity of the machine while in operation.

CHECK PACKAGE UPON ARRIVAL

Upon receipt of an Omcan shipment please inspect for external damage. If no damage is evident on the external packaging, open carton to ensure all ordered items are within the box, and there is no concealed damage to the machine. If the package has suffered rough handling, bumps or damage (visible or concealed), please note it on the bill of lading before accepting the delivery and contact Omcan within 24 hours, so we may initiate a claim with the carrier. A detailed report on the extent of the damage caused to the machine must be filled out within three days, from the delivery date shown in the shipping documents. Omcan has no recourse for damaged products that were shipped collect or third party.

Before operating any equipment, always read and familiarize yourself with all operation and safety instructions.

Omcan would like to thank you for purchasing this machine. It's of the utmost importance to save these instructions for future reference. Also save the original box and packaging for shipping the equipment if servicing or returning of the machine is required.

Omcan Fabrication et distribution Compañie Limité et Food Machinery d'Amérique, dba Omcan et Omcan Inc. ne sont pas responsables de tout dommage ou blessure causé du fait que toute personne ait utilisé cet équipement de façon irrégulière. Le produit ne doit être exploité que par quelqu'un de plus de 18 ans, saine d'esprit, et pas sous l'influence d'une drogue ou d'alcool, qui a été formé pour utiliser cette machine correctement, et est vêtu de vêtements de sécurité approprié. Toute modification de la machine annule toute garantie, et peut causer un préjudice à des personnes utilisant la machine ou des personnes à proximité de la machine pendant son fonctionnement.

VÉRIFIEZ LE COLIS DÈS RÉCEPTION

Dès réception d'une expédition d'Omcan veuillez inspecter pour dommages externes. Si aucun dommage n'est visible sur l'emballage externe, ouvrez le carton afin de s'assurer que tous les éléments commandés sont dans la boîte, et il n'y a aucun dommage dissimulé à la machine. Si le colis n'a subi aucune mauvaises manipulations, de bosses ou de dommages (visible ou cachée), notez-le sur le bond de livraison avant d'accepter la livraison et contactez Omcan dans les 24 heures qui suivent, pour que nous puissions engager une réclamation auprès du transporteur. Un rapport détaillé sur l'étendue des dommages causés à la machine doit être rempli dans un délai de trois jours, à compter de la date de livraison indiquée dans les documents d'expédition. Omcan n'a aucun droit de recours pour les produits endommagés qui ont été expédiés ou cueilli par un tiers transporteur.

General Information

Avant d'utiliser n'importe quel équipement, toujours lire et vous familiariser avec toutes les opérations et les consignes de sécurité.

Omcan voudrais vous remercier d'avoir choisi cette machine. Il est primordial de conserver ces instructions pour une référence ultérieure. Également conservez la boîte originale et l'emballage pour l'expédition de l'équipement si l'entretien ou le retour de la machine est nécessaire.

Omcan Empresa De Fabricacion Y Distribucion Inc. Y Maquinaria De Alimentos De America, Inc. dba Omcan y Omcan Inc. no son responsables de ningun daño o perjuicio causado por cualquier persona inadecuada o el uso descuidado de este equipo. El producto solo podra ser operado por una persona mayor de 18 años, en su sano juicio y no bajo alguna influencia de droga o alcohol, y que este ha sido entrenado en el correcto funcionamiento de esta máquina, y ésta usando ropa apropiada y autorizada. Cualquier modificación a la máquina anula la garantía y puede causar daños a las personas usando la máquina mientras esta en el funcionamiento.

REVISE EL PAQUETE A SU LLEGADA

Tras la recepcion de un envio Omcan favor inspeccionar daños externos. Si no hay daños evidentes en el empaque exterior, Habra el carton para asegurarse que todos los articulos solicitados estén dentro de la caja y no encuentre daños ocultos en la máquina. Si el paquete ha sufrido un manejo de poco cuidado, golpes o daños (visible o oculto) por favor anote en la factura antes de aceptar la entrega y contacte Omcan dentro de las 24 horas, de modo que podamos iniciar una reclamación con la compañía. Un informe detallado sobre los daños causados a la máquina debe ser llenado en el plazo de tres días, desde la fecha de entrega que se muestra en los documentos de envío. Omcan no tiene ningun recurso por productos dañados que se enviaron a recoger por terceros.

Antes de utilizar cualquier equipo, siempre lea y familiarizarse con todas las instrucciones de funcionamiento y seguridad.

Omcan le gustaría darle las gracias por la compra de esta máquina. Es de la mayor importancia para salvar estas instrucciones para futuras consultas. Además, guarda la caja original y el embalaje para el envío del equipo si servicio técnico o devolución de la máquina que se requiere.

Safety and Warranty

- Before use, make sure the power supply corresponds to what is shown on the rating plate or within this manual.
- It should be placed on a flat and stable surface.
- Check that all the parts are not loose and that the unit is in working order before operating.
- The unit must be in a well ventilated location to avoid a fire hazard.

RESIDENTIAL USERS: Vendor assumes no liability for parts or labor coverage for component failure



Safety and Warranty

or other damages resulting from installation in non-commercial or residential applications. The right is reserved to deny shipment for residential usage; if this occurs, you will be notified as soon as possible.

1 YEAR PARTS AND LABOUR BENCH WARRANTY

Within the warranty period, contact Omcan Inc. at 1-800-465-0234 to schedule a drop off to either an Omcan authorized service depot in the area, or to an Omcan Service warehouse to repair the equipment.

Unauthorized maintenance will void the warranty. Warranty covers electrical and part failures, not improper use.

Please see <https://omcan.com/disclaimer> for complete info.

WARNING:

The packaging components are classified as normal solid urban waste and can therefore be disposed of without difficulty.

In any case, for suitable recycling, we suggest disposing of the products separately (differentiated waste) according to the current norms.

DO NOT DISCARD ANY PACKAGING MATERIALS IN THE ENVIRONMENT!

Technical Specifications

Model	FW-CN-0905	FW-CN-1170	FW-CN-1435
Power	1.5 kW		1.8 kW
Pan Capacity	(3) 1/2-Size (1) Full Size & (1) 1/2-Size	(4) 1/2-Size (2) Full Size (1) Full Size & (2) 1/2-Size	(5) 1/2-Size (1) Full Size & (3) 1/2-Size (2) Full Size & (1) 1/2-Size
Temperature Range	30 - 85°C / 86 - 185°F		
Electrical	110V / 60Hz / 1		
Weight	31 lbs. / 14 kgs.	37 lbs. / 17 kgs.	44 lbs. / 20 kgs.
Packaging Weight	35 lbs. / 16 kgs.	42 lbs. / 19 kgs.	51 lbs. / 23 kgs.
Dimensions	13.6" x 36" x 12.5" 345 x 919 x 318mm	13.6" x 47" x 12.5" 345 x 1187 x 318mm	13.6" x 57" x 12.5" 345 x 1455 x 318mm
Packaging Dimensions	17" x 38" x 9.5" 432 x 965 x 241mm	17" x 50" x 10" 1270 x 432 x 254mm	16" x 60" x 11" 415 x 1525 x 280mm
Item Number	42156	42157	43055

Operation

1. Remove one pan, add water into the water box, the water box should only be filled halfway.
2. Turn the thermostat to zero.
3. Plug into the power supply, the indicator light will be red, adjust the temperature based on your needs, the green light will turn on and the heating process will begin. When the set temperature is reached, the thermostat will shut off the power and the green light will turn off. When the temperature gets too low, the thermostat will automatically start the heating process again until the set temperature is reached again. The cycle will repeat until desired.
4. When the temperature of pan has reached the desired setting, food may then be added immediately in the pan.
5. After working for an extended period of time, the water level will lower due to smoke volatilization.
6. Turn the thermostat to zero and remove from the power supply when completed operation.

Maintenance

The user must clean the machine after use, making sure to clean with mild detergent and a damp towel. Never clean this machine with running water or pressurized jets.

Note: Maintenance and cleaning procedures must be done ONLY when the machine is not in operation and unplugged from the power supply.

Parts Breakdown

Model FW-CN-0905 42156

Model FW-CN-1170 42157

Model FW-CN-1435 43055

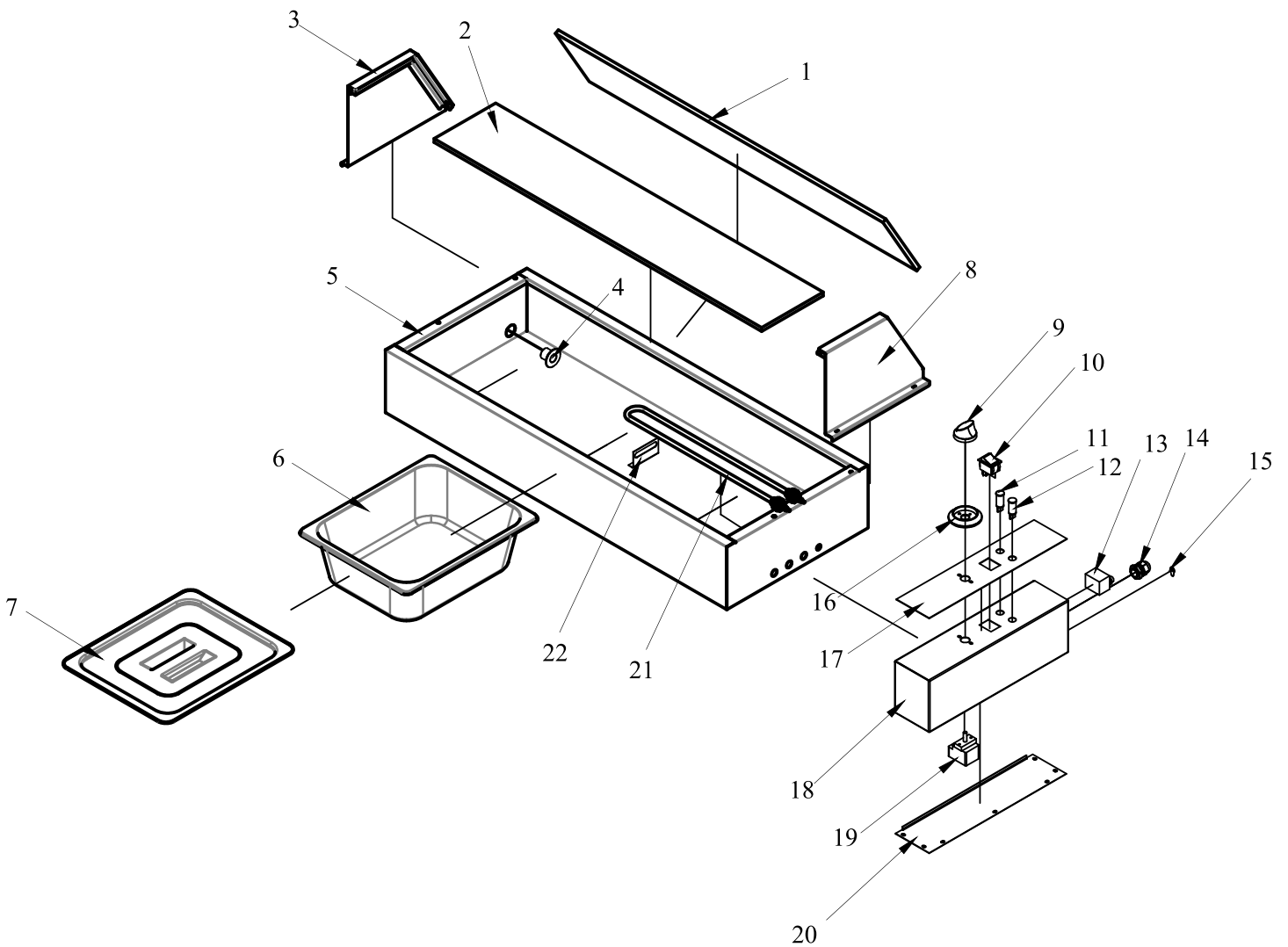

Parts Breakdown

Model FW-CN-0905 42156

Item No.	Description	Position	Item No.	Description	Position	Item No.	Description	Position
60223	Front Glass 827x165 for 42156	1	60239	Temperature Controller Knob for 42156	9, 16	60235	PVC for 42156	17
60222	Top Glass 827x150 for 42156	2	68267	UL Switch for 42156	10	60232	Control Box for 42156	18
61418	Brackets and Hardware Kit for 42156	3, 8	60237	Power Light (Green) for 42156	11	60231	Temperature Controller for 42156	19
66038	Drain Nozzle for 42156	4	60236	Heat Light (Orange) for 42156	12	60230	Control Box Bottom Board for 42156	20
60227	Body for 42156	5	60233	Temperature Limiter for 42156	13	60250	Heating Pipe for 42156	21
60242	1/2x10 Stainless Steel Container for 42156	6	66039	Plastic Cable Head for 42156	14	60228	Heating Pipe Support for 42156	22
60263	1/2 PC Cover of Container for 42156	7	60234	Ground Terminal for 42156	15	AC953	Assembled Complete Body for 42156	

Model FW-CN-1170 42157

Item No.	Description	Position	Item No.	Description	Position	Item No.	Description	Position
60244	Front Glass 1095x165 for 42157	1	60239	Temperature Controller Knob for 42157	9, 16	60235	PVC for 42157	17
60243	Top Glass 1095x150 for 42157	2	68267	UL Switch for 42157	10	60253	Control Box for 42157	18
61418	Brackets and Hardware Kit for 42157	3, 8	60237	Power Light (Green) for 42157	11	60231	Temperature Controller for 42157	19
66038	Drain Nozzle for 42157	4	60236	Heat Light (Orange) for 42157	12	60230	Control Box Bottom Board for 42157	20
60248	Body for 42157	5	60233	Temperature Limiter for 42157	13	60250	Heating Pipe for 42157	21
60242	1/2x10 Stainless Steel Container for 42157	6	66039	Plastic Cable Head for 42157	14	60228	Heating Pipe Support for 42157	22
60263	1/2 PC Cover of Container for 42157	7	60234	Ground Terminal for 42157	15	AC954	Assembled Complete Body for 42157	

Model FW-CN-1435 43055

Item No.	Description	Position	Item No.	Description	Position	Item No.	Description	Position
60265	Front Glass 1363x165 for 43055	1	60239	Temperature Controller Knob for 43055	9, 16	60235	PVC for 43055	17
60264	Top Glass 1363x150 for 43055	2	68267	UL Switch for 43055	10	60274	Control Box for 43055	18
61418	Brackets and Hardware Kit for 43055	3, 8	60237	Power Light (Green) for 43055	11	60231	Temperature Controller for 43055	19
66038	Drain Nozzle for 43055	4	60236	Heat Light (Orange) for 43055	12	60230	Control Box Bottom Board for 43055	20
60269	Body and Control Box for 43055	5	60233	Temperature Limiter for 43055	13	60271	Heating Pipe for 43055	21
60242	1/2x10 Stainless Steel Container for 43055	6	66039	Plastic Cable Head for 43055	14	60228	Heating Pipe Support for 43055	22
60263	1/2 PC Cover of Container for 43055	7	60234	Ground Terminal for 43055	15	AC955	Assembled Complete Body for 43055	

Electrical Schematics

Model FW-CN-0905 42156

Model FW-CN-1170 42157

Model FW-CN-1435 43055

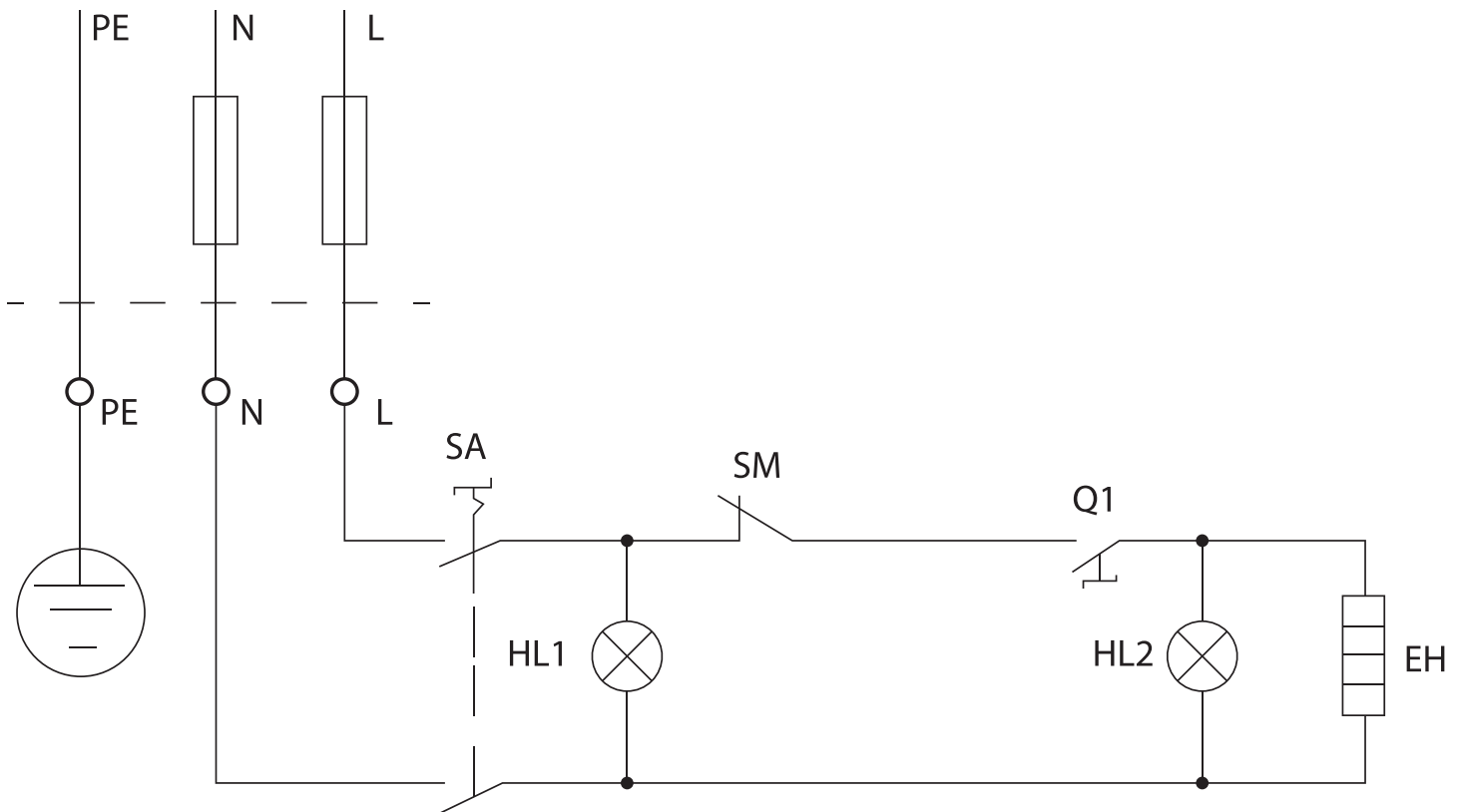

EH: Heat

SM: Limiter

HL: Indicator Light

Q1: Temperature Controller

SA: Main Switch



Warranty Registration

Thank you for purchasing an Omcan product. To register your warranty for this product, complete the information below, tear off the card at the perforation and then send to the address specified below. You can also register online by visiting:

Merci d'avoir acheté un produit Omcan. Pour enregistrer votre garantie pour ce produit, complétez les informations ci-dessous, détachez la carte au niveau de la perforation, puis l'envoyer à l'adresse spécifiée ci-dessous. Vous pouvez également vous inscrire en ligne en visitant:

Gracias por comprar un producto Omcan usted. Para registrar su garantía para este producto, complete la información a continuación, cortar la tarjeta en la perforación y luego enviarlo a la dirección indicada a continuación. También puede registrarse en línea en:

<https://omcan.com/warranty-registration/>

For mailing in Canada

Pour postale au Canada

Por correo en Canadá

OMCAN

PRODUCT WARRANTY REGISTRATION

3115 Pepper Mill Court,

Mississauga, Ontario

Canada, L5L 4X5

For mailing in the US

Pour diffusion aux États-Unis

Por correo en los EE.UU.

OMCAN

PRODUCT WARRANTY REGISTRATION

4450 Witmer Industrial Estates, Unit 4,

Niagara Falls, New York

USA, 14305

or email to: service@omcan.com



Purchaser's Information

Name: _____

Address: _____

City: _____ Province or State: _____ Postal or Zip: _____

Country: _____

Dealer from which Purchased: _____

Dealer City: _____ Dealer Province or State: _____

Invoice: _____

Model Name: _____ Model Number: _____

Machine Description: _____

Date of Purchase (MM/DD/YYYY): _____

Would you like to extend the warranty? Yes No

Company Name: _____

Telephone: _____

Email Address: _____

Type of Company:

Restaurant Bakery Deli

Butcher Supermarket Caterer

Institution (*specify*): _____

Other (*specify*): _____

Serial Number: _____

Date of Installation (MM/DD/YYYY): _____

Thank you for choosing Omcan | Merci d'avoir choisi Omcan | Gracias por elegir Omcan



Since 1951 Omcan has grown to become a leading distributor of equipment and supplies to the North American food service industry. Our success over these many years can be attributed to our commitment to strengthen and develop new and existing relationships with our valued customers and manufacturers. Today with partners in North America, Europe, Asia and South America, we continually work to improve and grow the company. We strive to offer customers exceptional value through our qualified local sales and service representatives who provide convenient access to over 6,500 globally sourced products.

Depuis 1951 Omcan a grandi pour devenir un des “leaders” de la distribution des équipements et matériel pour l’industrie des services alimentaires en Amérique du Nord. Notre succès au cours de ces nombreuses années peut être attribué à notre engagement à renforcer et à développer de nouvelles et existantes relations avec nos clients et les fabricants de valeur. Aujourd’hui avec des partenaires en Amérique du Nord, Europe, Asie et Amérique du Sud, nous travaillons continuellement à améliorer et développer l’entreprise. Nous nous efforçons d’offrir à nos clients une valeur exceptionnelle grâce à nos ventes locales qualifiées et des représentants de service qui offrent un accès facile à plus de 6500 produits provenant du monde entier.

Desde 1951 Omcan ha crecido hasta convertirse en un líder en la distribución de equipos y suministros de alimentos en América del Norte industria de servicios. Nuestro éxito en estos años se puede atribuir a nuestro compromiso de fortalecer y desarrollar nuevas relaciones existentes con nuestros valiosos clientes y fabricantes. Hoy con socios de América del Norte, Europa, Asia y América del Sur, que trabajan continuamente para mejorar y crecer la empresa. Nos esforzamos por ofrecer a nuestros clientes valor excepcional a través de nuestro local de ventas y representantes de los servicios que proporcionan un fácil acceso a más de 6,500 productos con origen a nivel mundial.

